

# AQUALINE BY ALWAY

## AQUALINE

### AQEDA110RTB

#### Product Description

The Aqualine Edan Round Top  $\varnothing 110\text{mm}$  Bottom Gully is specifically designed for sink waste, where shallow pipe inverts occur and connects directly to sub terrain drainage pipes.

Fitted with a removable debris cover, to prevent blockages, the Edan Gully is easy to clean and provides an ideal solution for environments that require high standards of cleanliness.

This product is available in one standard size, with a variable filtration mesh hole size, to accommodate a variety of flow rates.

#### Key Benefits

- Manufactured in England
- In-house bespoke design service
- Designed to be durable and easy to clean
- Ideal for food grade environments
- Easy installation
- Suitable for pedestrian factory traffic
- Load Class up to FACTA A15
- Fitting and installation service available
- Maintenance & inspection contracts available
- Bead Blasted
- Rodding access for easy cleaning
- Gully cover removal tools available
- Gully membrane flange available
- Lockable Gully cover available

#### Technical Specification

- 1.5mm stainless steel
- 1.5mm stainless steel trap
- Available in one standard size
- Grade 304 or 316 stainless steel (British Standard 304S31, Euronorm 1.4301)
- Removable debris cover
- Ideal for sink waste
- Round opening with smooth cover
- Variable filtration mesh hole size
- Range of matching gully covers available
- Square top plate for tiling.

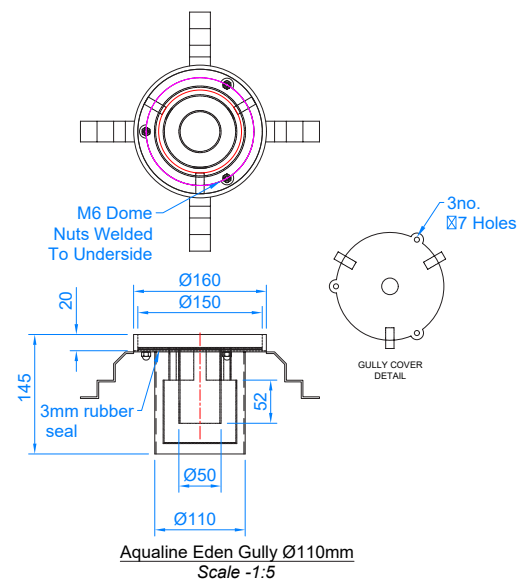

## Drainage Systems

The Aqualine range keeps things flowing with hygienic, durable and low maintenance drainage solutions, suitable for use in food-grade environments.

Made from high quality stainless steel in our state-of-the-art facility, all Aqualine products are designed by our in-house engineers and manufactured in the UK.

In addition to a wide range of off the shelf options, we offer a bespoke design service, enabling us to customise and create products to meet any customer requirements.



## Maintenance

Stainless steel equipment should be routinely checked for concentrated fluid build up, retained deposits and damage as these can lead to corrosion. If required, we are able to provide planned preventative maintenance programmes and inspections to ensure that drainage systems are in optimal operating condition.

## Cleaning

All of our Aqualine range is designed to be easy to clean and maintain. The recommended cleaning methods include; steam, water, non-abrasive scrubbing, organic solvents and mild detergents. The frequency and specific cleaning method used will depend on the application of the drainage. All products should be routinely checked for damage.

## Installation

Our dedicated installation team are capable of undertaking projects of any scale with assistance and expertise provided at every stage of the project. All installations adhere to our industry leading service standards, are handed over ready to use and include a high quality finish with welded and polished joints and commissioning included. Installation services are available on all product ranges and bespoke products.

## Additional options

We offer a bespoke design service for our drainage systems to meet the requirements of your workplace or project.

To discuss a project, or bespoke design requirement, contact our technical sales department.

01509611235  
www.alwayaqualine.co.uk  
enquiries@alwayaqualine.co.uk

