

# Swept single branch 87,5°

## Product information for the product group

### ACO Product benefits

ACO pipe used together with other ACO drainage products provides **complex building drainage solution:**

- Hygienic design following EN 1672, EN ISO 14159 and EHEDG document 8, 13 and 44
- Resistant to thermal and dynamic shocks
- Fast, reliable and cost-effective installation
- Sagging-proof
- Non-combustible
- Rodent-proof

- Stainless steel ACO pipe system is **designed for gray and black water, rainwater and industrial waste water drainage applications**
- Suitable for both **syphonic, vacuum and gravity drainage solutions**
- **Double lip seal push-fit connection** for easy and reliable installation

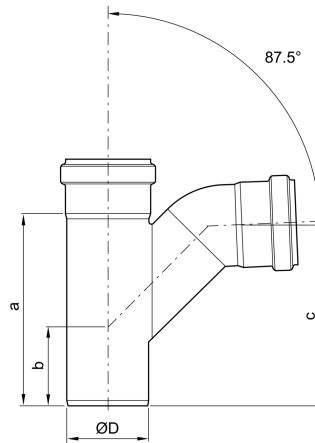

## Item Technical Data 98818

Nominal pipe size	Angle $\alpha$	Dimensions				Material	Seal	Weight
		D [mm]	a [mm]	b [mm]	c [mm]			
DN 110	87,5°	110	233	88	209	1.4301	EPDM	1.10