

Long bend 87,5°

Product information for the product group

ACO Product benefits

ACO pipe used together with other ACO drainage products provides **complex building drainage solution:**

- Hygienic design following EN 1672, EN ISO 14159 and EHEDG document 8, 13 and 44
- Resistant to thermal and dynamic shocks
- Fast, reliable and cost-effective installation
- Sagging-proof
- Non-combustible
- Rodent-proof

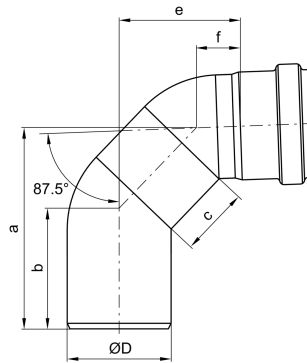

- Stainless steel ACO pipe system is **designed for gray and black water, rainwater and industrial waste water drainage applications**
- Suitable for both **syphonic, vacuum and gravity drainage solutions**
- **Double lip seal push-fit connection** for easy and reliable installation

Item Technical Data 419150

Nominal pipe size	Angle α	Dimensions						Material	Seal	Weight
		D	a	b	c	e	f			
		[mm]	[mm]	[mm]	[mm]	[mm]	[mm]			
DN 110	87,5°	110	316	103	250	246	39	1.4301	EPDM	1.40