

AQUALINE BY ALWAYS

KERBLINE

AQC3 Clip on kerb

Product Description

The Kerbline AQC3 Clip On Wall Kerb provides an interface between wall panelling and floor level, offering support, improving hygiene, mitigating liquid ingress and safeguarding your space.

This product is mounted on the front facing of block walls and freezer panels, continuing the silhouette of the surrounding Kerb.

Suitable for use with a with 6-9 mm resin flooring. The AQC3 Kerb can be customised to meet specific customer requirements.

Key Benefits

- Manufactured in England.
- Available in a variety of sizes and styles.
- In-house bespoke design service.
- Designed to be durable and easy to clean.
- Ideal for food grade environments.
- Fitting and installation service available.
- Range of thicknesses available
- Concrete infill available if required.
- Fully welded.
- Maintenance & inspection contracts available
- Suitable for sliding, personnel, roller doors, corners, tees, wall ends & columns.
- Easy removal if required.

Technical Specification

- 2mm 240 grit stainless steel.
- Internal galvanised mild steel channel back plate.
- The profile of the kerb is dependent on wall thickness.
- Resin anchor fixings.
- Available in grade 316 stainless steel (British Standard 316S31, Euronorm 1.4401).
- British Galvanised Standard BS EN ISO 1461:2009.

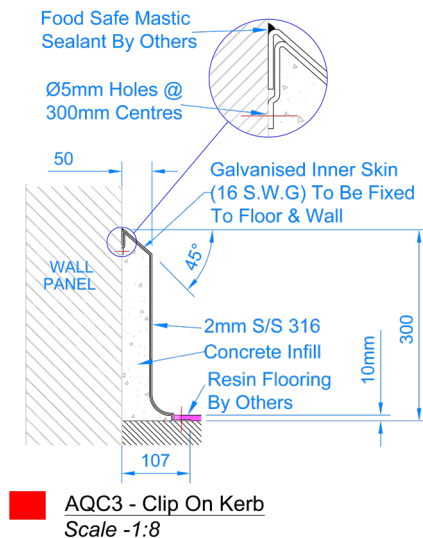

Kerbing Systems

The Kerblin range provides a hygienic, durable and low maintenance kerbing solution, suitable for use in food-grade environments.

Made from high quality stainless steel in our state-of-the-art facility, all Kerblin products are designed by our in-house engineers and manufactured in the UK.

In addition to a wide range of off the shelf options, we offer a bespoke design service, enabling us to customise and create products to meet any customer requirements.

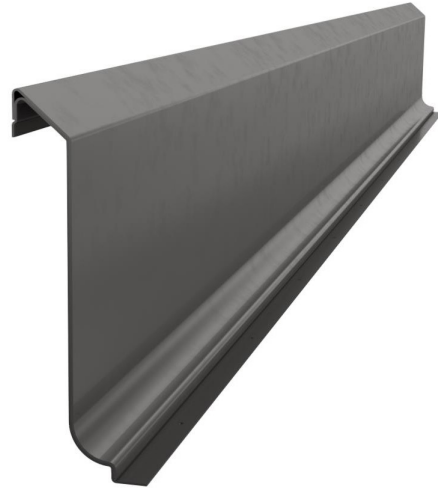

Maintenance

Stainless steel equipment should be routinely checked for concentrated fluid build up, retained deposits and damage as these can lead to corrosion. If required, we are able to provide planned preventative maintenance programmes and inspections to ensure that kerbing systems are in optimal operating condition.

Cleaning

All of our kerbing is designed to be easy to clean and maintain. The recommended cleaning methods include; steam, water, non-abrasive scrubbing, organic solvents and mild detergents. The frequency and specific cleaning method used will depend on the application of the kerbing. All kerbing should be routinely checked for damage.

Installation

Our dedicated installation team are capable of undertaking projects of any scale with assistance and expertise provided at every stage of the project. All installations adhere to our industry leading service standards, are handed over ready to use and include a high quality finish with welded and polished joints and commissioning included. Installation services are available on all product ranges and bespoke products.

Additional options

We offer a selection of resin flooring options to compliment this kerbing range.

To discuss a project, or bespoke design requirement, contact our technical sales department.

01509611235
www.alwayaqualine.co.uk
enquiries@alwayaqualine.co.uk

