

KERBLINE

AQA2 Double Sided Kerb

Product Description

The Kerbline AQA2 Double Sided Kerbing system provides an interface between wall panelling and floor level, offering support, improving hygiene, mitigating liquid ingress and safeguarding your space. Manufactured in England and made from high quality stainless steel, the AQA2 kerb is suitable for use with pre-existing flooring and can be mounted around columns and block walls.

This product can be customised to meet specific customer requirements.

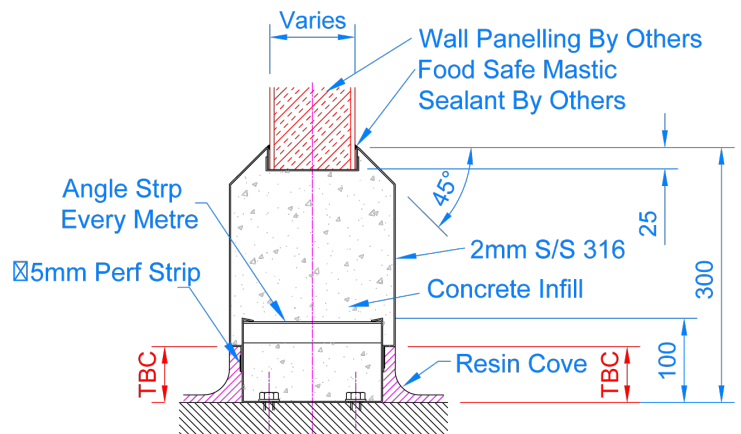

AQA2 Double Sided Kerb
Scale -1:8

Key Benefits

- Manufactured in England
- Available in a variety of sizes and styles
- In-house bespoke design service
- Designed to be durable and easy to clean
- Ideal for food grade environments
- Easy to install on existing floors
- Fitting and installation service available
- Concrete infill available if required.
- Fully welded
- Suitable for sliding, personnel, roller doors, corners, tees, wall ends & columns
- Maintenance & inspection contracts available

Technical Specification

- 2mm 240 grit stainless steel.
- Internal galvanised mild steel channel support.
- Available in grade 316 stainless steel (British Standard 316S31, Euronorm 1.4401)
- Resin anchor fixings.
- British Galvanised Standard BS EN ISO 1461:2009.

Kerbing Systems

The Kerblin range provides a hygienic, durable and low maintenance kerbing solution, suitable for use in food-grade environments.

Made from high quality stainless steel in our state-of-the-art facility, all Kerblin products are designed by our in-house engineers and manufactured in the UK.

In addition to a wide range of off the shelf options, we offer a bespoke design service, enabling us to customise and create products to meet any customer requirements.



Maintenance

Stainless steel equipment should be routinely checked for concentrated fluid build up, retained deposits and damage as these can lead to corrosion. If required, we are able to provide planned preventative maintenance programmes and inspections to ensure that kerbing systems are in optimal operating condition.

Cleaning

All of our kerbing is designed to be easy to clean and maintain. The recommended cleaning methods include; steam, water, non-abrasive scrubbing, organic solvents and mild detergents. The frequency and specific cleaning method used will depend on the application of the kerbing. All kerbing should be routinely checked for damage.

Installation

Our dedicated installation team are capable of undertaking projects of any scale with assistance and expertise provided at every stage of the project. All installations adhere to our industry leading service standards, are handed over ready to use and include a high quality finish with welded and polished joints and commissioning included. Installation services are available on all product ranges and bespoke products.

Additional options

We offer a selection of resin flooring options to compliment this kerbing range.

To discuss a project, or bespoke design requirement, contact our technical sales department.

01509611235
www.alwayaqualine.co.uk
enquiries@alwayaqualine.co.uk

